



CU 800i
CU 1100i
CU 1400i

EN

Operating instructions

Cooling unit

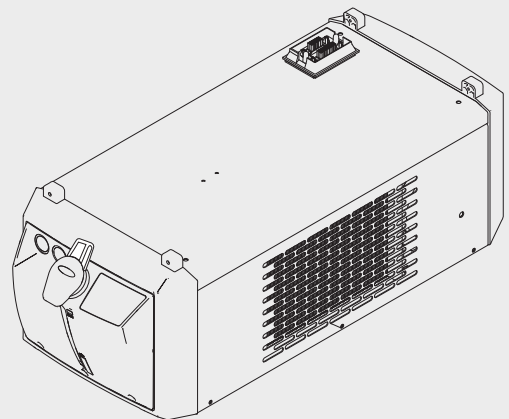

42,0426,0115,EN 034-15042021

Contents

Safety rules.....	5
Explanation of safety notices.....	5
General.....	5
Proper use.....	5
Environmental conditions.....	6
Obligations of the operator.....	6
Obligations of personnel.....	6
Mains connection.....	6
Protecting yourself and others.....	7
Noise emission values.....	7
Danger from toxic gases and vapours.....	8
Danger from flying sparks.....	8
Risks from mains current and welding current.....	9
Meandering welding currents.....	10
EMC Device Classifications.....	10
EMC measures.....	10
EMF measures.....	11
Specific hazards.....	11
Requirement for the shielding gas.....	12
Danger from shielding gas cylinders.....	12
Danger from escaping shielding gas.....	13
Safety measures at the installation location and during transport.....	13
Safety measures in normal operation.....	13
Commissioning, maintenance and repair.....	14
Safety inspection.....	14
Disposal.....	15
Safety symbols.....	15
Data protection.....	15
Copyright.....	15
General information.....	17
General.....	19
Device concept.....	19
Device versions.....	19
Application area.....	20
Scope of supply.....	20
Validity of "General Delivery and Payment Conditions".....	20
Coolant pump service life in cooling units for single-shift operation.....	20
Coolant pump service life in cooling units for multi-shift operation.....	21
General.....	21
Information about the coolant.....	21
Information on leaks.....	22
Warning notices on the device.....	22
Options.....	24
OPT/i CU flow temperature sensor.....	24
OPT CU coolant filter.....	25
OPT/i CU level sensor.....	25
OPT CU front coolant connections.....	25
OPT/i CU Torch deflate.....	25
Connections and mechanical components.....	27
Connections and mechanical components.....	29
Connections and mechanical components: CU 1100i, CU 1100i /460V, CU 1100i /MV, CU 1100i /MV RVP, CU 1400i Pro, CU 1400i Pro /MC.....	29
Connections and mechanical components: CU 800i, CU 800i /460 V, CU 800i Pro.....	30
Installation and commissioning.....	31
Before installation and commissioning.....	33

Safety.....	33
Setup regulations.....	33
Information about the coolant.....	34
Guarantee provisions regarding the coolant pump.....	34
Proper use.....	34
Fitting the cooling unit to the trolley.....	35
General.....	35
Fitting the cooling unit to trolley.....	35
Connecting the cooling unit to the power source.....	36
Safety.....	36
Connecting the cooling unit to the power source.....	36
Connect the coolant hoses to the cooling unit.....	38
Safety.....	38
Connecting the interconnecting hosepack coolant hoses to the cooling unit.....	38
TPS 270i C, TPS 320i C, TT 300i - 500i, MW 300i - 500i: connecting the welding torch coolant hoses to the cooling unit.....	38
Filling and starting up the cooling unit.....	39
Filling the cooling unit.....	39
Starting up the cooling unit.....	40
OPT/i CU Torch deflate: Emptying/filling the torch hosepack.....	41
Operating modes.....	42
Recommended application of the operating modes.....	43
Disconnect the cooling unit from the power source.....	44
Safety.....	44
Disconnecting the cooling unit from the power source.....	44
Fitting the coolant filter option.....	46
Safety.....	46
Fitting the coolant filter option.....	46
Troubleshooting	47
Troubleshooting.....	49
Safety.....	49
Troubleshooting.....	49
Turning the coolant pump shaft on the CU 800i, CU 1100i, CU 1100i /MV.....	52
Safety.....	52
Turning the coolant pump shaft.....	52
Care, maintenance and disposal	53
Care, maintenance and disposal.....	55
Safety.....	55
General.....	55
Symbols for care and maintenance of the cooling unit.....	56
Maintenance intervals, maintenance work.....	56
Gas purging the cooler.....	57
Change the coolant.....	58
Disposal.....	60
Technical data	61
Technical data.....	63
General.....	63
CU 800i, CU 800i /460 V.....	63
CU 800i Pro.....	65
CU 1100i, CU 1100i /460 V.....	66
CU 1100i /MV, CU 1100i /MV RVP.....	68
CU 1400i Pro, CU 1400i Pro /MC.....	70

Safety rules

Explanation of safety notices

DANGER!

Indicates **immediate danger**.

- ▶ If not avoided, death or serious injury will result.

WARNING!

Indicates a **potentially hazardous situation**.

- ▶ If not avoided, death or serious injury may result.

CAUTION!

Indicates a **situation where damage or injury could occur**.

- ▶ If not avoided, minor injury and/or damage to property may result.

NOTE!

Indicates a **risk of flawed results and possible damage to the equipment**.

General

The device is manufactured using state-of-the-art technology and according to recognised safety standards. If used incorrectly or misused, however, it can cause:

- injury or death to the operator or a third party,
- damage to the device and other material assets belonging to the operating company,
- inefficient operation of the device.

All persons involved in commissioning, operating, maintaining and servicing the device must:

- be suitably qualified,
- have sufficient knowledge of welding and
- read and follow these operating instructions carefully.

The operating instructions must always be at hand wherever the device is being used. In addition to the operating instructions, attention must also be paid to any generally applicable and local regulations regarding accident prevention and environmental protection.

All safety and danger notices on the device

- must be in a legible state,
- must not be damaged,
- must not be removed,
- must not be covered, pasted or painted over.

For the location of the safety and danger notices on the device, refer to the section headed "General" in the operating instructions for the device.

Before switching on the device, rectify any faults that could compromise safety.

This is for your personal safety!

Proper use

The device is to be used exclusively for its intended purpose.

The device is intended solely for the welding processes specified on the rating plate. Any use above and beyond this purpose is deemed improper. The manufacturer shall not be held liable for any damage arising from such usage.

Proper use includes:

- carefully reading and following all the instructions given in the operating instructions
 - studying and obeying all safety and danger notices carefully
 - performing all stipulated inspection and maintenance work.
-

Never use the device for the following purposes:

- Thawing out pipes
 - Charging batteries
 - Starting engines
-

The device is designed for use in industry and the workshop. The manufacturer accepts no responsibility for any damage caused through use in a domestic setting.

The manufacturer likewise accepts no liability for inadequate or incorrect results.

Environmental conditions

Operation or storage of the device outside the stipulated area will be deemed as not in accordance with the intended purpose. The manufacturer shall not be held liable for any damage arising from such usage.

Ambient temperature range:

- during operation: -10 °C to + 40 °C (14 °F to 104 °F)
 - during transport and storage: -20 °C to +55 °C (-4 °F to 131 °F)
-

Relative humidity:

- up to 50% at 40 °C (104 °F)
 - up to 90% at 20 °C (68 °F)
-

The surrounding air must be free from dust, acids, corrosive gases or substances, etc. Can be used at altitudes of up to 2000 m (6561 ft. 8.16 in.)

Obligations of the operator

The operator must only allow persons to work with the device who:

- are familiar with the fundamental instructions regarding safety at work and accident prevention and have been instructed in how to use the device
 - have read and understood these operating instructions, especially the section "safety rules", and have confirmed as much with their signatures
 - are trained to produce the required results.
-

Checks must be carried out at regular intervals to ensure that operators are working in a safety-conscious manner.

Obligations of personnel

Before using the device, all persons instructed to do so undertake:

- to observe the basic instructions regarding safety at work and accident prevention
 - to read these operating instructions, especially the "Safety rules" section and sign to confirm that they have understood them and will follow them.
-

Before leaving the workplace, ensure that people or property cannot come to any harm in your absence.

Mains connection

Devices with a higher rating may affect the energy quality of the mains due to their current consumption.

This may affect a number device types in terms of:

- Connection restrictions
- Criteria with regard to the maximum permissible mains impedance ^{*)}
- Criteria with regard to the minimum short-circuit power requirement ^{*)}

^{*)} at the interface with the public grid
see "Technical data"

In this case, the plant operator or the person using the device should check whether the device may be connected, where appropriate by discussing the matter with the power supply company.

IMPORTANT! Ensure that the mains connection is earthed properly

Protecting yourself and others

Anyone working with the device exposes themselves to numerous risks, e.g.

- flying sparks and hot pieces of metal
- Arc radiation, which can damage eyes and skin
- Hazardous electromagnetic fields, which can endanger the lives of those using cardiac pacemakers
- Risk of electrocution from mains current and welding current
- Greater noise pollution
- Harmful welding fumes and gases

Suitable protective clothing must be worn when working with the device. The protective clothing must have the following properties:

- Flame-resistant
- Insulating and dry
- Covers the whole body, is undamaged and in good condition
- Safety helmet
- Trousers with no turn-ups

Protective clothing refers to a variety of different items. Operators should:

- Protect eyes and face from UV rays, heat and sparks using a protective visor and regulation filter
- Wear regulation protective goggles with side protection behind the protective visor
- Wear stout footwear that provides insulation even in wet conditions
- Protect the hands with suitable gloves (electrically insulated and providing protection against heat)
- Wear ear protection to reduce the harmful effects of noise and to prevent injury

Keep all persons, especially children, out of the working area while any devices are in operation or welding is in progress. If, however, there are people in the vicinity:

- Make them aware of all the dangers (risk of dazzling by the arc, injury from flying sparks, harmful welding fumes, noise, possible risks from mains current and welding current, etc.)
- Provide suitable protective equipment
- Alternatively, erect suitable safety screens/curtains.

Noise emission values

The device generates a maximum sound power level of <80 dB(A) (ref. 1pW) when idling and in the cooling phase following operation at the maximum permissible operating point under maximum rated load conditions according to EN 60974-1.

It is not possible to provide a workplace-related emission value during welding (or cutting) as this is influenced by both the process and the environment. All manner of different welding parameters come into play, including the welding process (MIG/MAG, TIG welding), the type of power selected (DC or AC), the power range, the type of weld metal, the resonance characteristics of the workpiece, the workplace environment, etc.

Danger from toxic gases and vapours

The fumes produced during welding contain harmful gases and vapours.

Welding fumes contain substances that cause cancer, as stated in Monograph 118 of the International Agency for Research on Cancer.

Use at-source extraction and a room extraction system.
If necessary, use a welding torch with an integrated extraction device.

Keep your face away from welding fumes and gases.

Fumes and hazardous gases

- must not be breathed in
- must be extracted from the working area using appropriate methods.

Ensure an adequate supply of fresh air. Ensure that there is a ventilation rate of at least 20 m³ per hour at all times.

Otherwise, a welding helmet with an air supply must be worn.

If there is any doubt about whether the extraction capacity is sufficient, the measured toxic emission values should be compared with the permissible limit values.

The following components are responsible, amongst other things, for the degree of toxicity of welding fumes:

- Metals used for the workpiece
- Electrodes
- Coatings
- Cleaners, degreasers, etc.
- Welding process used

The relevant material safety data sheets and manufacturer's specifications for the listed components should therefore be studied carefully.

Recommendations for trade fair scenarios, risk management measures and for identifying working conditions can be found on the European Welding Association website under Health & Safety (<https://european-welding.org>).

Flammable vapours (e.g. solvent fumes) should be kept away from the arc's radiation area.

Close the shielding gas cylinder valve or main gas supply if no welding is taking place.

Danger from flying sparks

Flying sparks may cause fires or explosions.

Never weld close to flammable materials.

Flammable materials must be at least 11 metres (36 ft. 1.07 in.) away from the arc, or alternatively covered with an approved cover.

A suitable, tested fire extinguisher must be available and ready for use.

Sparks and pieces of hot metal may also get into adjacent areas through small gaps or openings. Take appropriate precautions to prevent any danger of injury or fire.

Welding must not be performed in areas that are subject to fire or explosion or near sealed tanks, vessels or pipes unless these have been prepared in accordance with the relevant national and international standards.

Do not carry out welding on containers that are being or have been used to store gases, propellants, mineral oils or similar products. Residues pose an explosive hazard.

Risks from mains current and welding current

An electric shock is potentially life threatening and can be fatal.

Do not touch live parts either inside or outside the device.

During MIG/MAG welding and TIG welding, the welding wire, the wirespool, the feed rollers and all pieces of metal that are in contact with the welding wire are live.

Always set the wirefeeder up on a sufficiently insulated surface or use a suitable, insulated wirefeeder holder.

Make sure that you and others are protected with an adequately insulated, dry base or cover for the earth or ground potential. This base or cover must extend over the entire area between the body and the earth or ground potential.

All cables and leads must be secured, undamaged, insulated and adequately dimensioned. Replace loose connections and scorched, damaged, or inadequately dimensioned cables and leads immediately.

Use the handle to ensure the power connections are tight before every use.

In the case of power cables with a bayonet connector, rotate the power cable around the longitudinal axis by at least 180° and pretension.

Do not wrap cables or leads around the body or parts of the body.

The electrode (rod electrode, tungsten electrode, welding wire, etc.) must

- never be immersed in liquid for cooling
- Never touch the electrode when the power source is switched on.

Double the open circuit voltage of a power source can occur between the welding electrodes of two power sources. Touching the potentials of both electrodes at the same time may be fatal under certain circumstances.

Arrange for the mains cable to be checked regularly by a qualified electrician to ensure the ground conductor is functioning properly.

Protection class I devices require a mains supply with ground conductor and a connector system with ground conductor contact for proper operation.

Operation of the device on a mains supply without ground conductor and on a socket without ground conductor contact is only permitted if all national regulations for protective separation are observed.

Otherwise, this is considered gross negligence. The manufacturer shall not be held liable for any damage arising from such usage.

If necessary, provide adequate earthing for the workpiece.

Switch off unused devices.

Wear a safety harness if working at height.

Before working on the device, switch it off and pull out the mains plug.

Attach a clearly legible and easy-to-understand warning sign to the device to prevent anyone from plugging the mains plug back in and switching it on again.

After opening the device:

- Discharge all live components
- Ensure that all components in the device are de-energised.

If work on live parts is required, appoint a second person to switch off the main switch at the right moment.

Meandering welding currents

If the following instructions are ignored, meandering welding currents can develop with the following consequences:

- Fire hazard
- Overheating of parts connected to the workpiece
- Irreparable damage to ground conductors
- Damage to device and other electrical equipment

Ensure that the workpiece is held securely by the workpiece clamp.

Attach the workpiece clamp as close as possible to the area that is to be welded.

Position the device with sufficient insulation against electrically conductive environments, e.g. Insulation against conductive floor or insulation to conductive racks.

If distribution boards, twin-head mounts, etc., are being used, note the following: The electrode of the welding torch / electrode holder that is not used is also live. Make sure that the welding torch / electrode holder that is not used is kept sufficiently insulated.

In the case of automated MIG/MAG applications, ensure that only an insulated wire electrode is routed from the welding wire drum, large wirefeeder spool or wirespool to the wirefeeder.

EMC Device Classifications

Devices in emission class A:

- Are only designed for use in industrial settings
- Can cause line-bound and radiated interference in other areas

Devices in emission class B:

- Satisfy the emissions criteria for residential and industrial areas. This is also true for residential areas in which the energy is supplied from the public low-voltage mains.

EMC device classification as per the rating plate or technical data.

EMC measures

In certain cases, even though a device complies with the standard limit values for emissions, it may affect the application area for which it was designed (e.g. when there is sensitive equipment at the same location, or if the site where the device is installed is close to either radio or television receivers).

If this is the case, then the operator is obliged to take appropriate action to rectify the situation.

Check and evaluate the immunity to interference of nearby devices according to national and international regulations. Examples of equipment that may be susceptible to interference from the device include:

- Safety devices
- Power, signal and data transfer lines
- IT and telecommunications devices
- Measuring and calibrating devices

Supporting measures for avoidance of EMC problems:

1. Mains supply
 - If electromagnetic interference arises despite correct mains connection, additional measures are necessary (e.g. use a suitable line filter).
2. Welding power leads
 - must be kept as short as possible
 - must run close together (to avoid EMF problems)
 - must be kept well apart from other leads
3. Equipotential bonding
4. Earthing of the workpiece
 - If necessary, establish an earth connection using suitable capacitors.

5. Shielding, if necessary
 - Shield off other nearby devices
 - Shield off entire welding installation

EMF measures

Electromagnetic fields may pose as yet unknown risks to health:

- effects on the health of others in the vicinity, e.g. wearers of pacemakers and hearing aids
- wearers of pacemakers must seek advice from their doctor before approaching the device or any welding that is in progress
- for safety reasons, keep distances between the welding cables and the welder's head/torso as large as possible
- do not carry welding cables and hosepacks over the shoulders or wind them around any part of the body

Specific hazards

Keep hands, hair, clothing and tools away from moving parts. For example:

- Fans
- Cogs
- Rollers
- Shafts
- Wirespools and welding wires

Do not reach into the rotating cogs of the wire drive or into rotating drive components.

Covers and side panels may only be opened/removed while maintenance or repair work is being carried out.

During operation

- Ensure that all covers are closed and all side panels are fitted properly.
- Keep all covers and side panels closed.

The welding wire emerging from the welding torch poses a high risk of injury (piercing of the hand, injuries to the face and eyes, etc.).

Therefore always keep the welding torch away from the body (devices with wire-feed unit) and wear suitable protective goggles.

Never touch the workpiece during or after welding - risk of burns.

Slag can jump off cooling workpieces. The specified protective equipment must therefore also be worn when reworking workpieces, and steps must be taken to ensure that other people are also adequately protected.

Welding torches and other parts with a high operating temperature must be allowed to cool down before handling.

Special provisions apply in areas at risk of fire or explosion - observe relevant national and international regulations.

Power sources for work in areas with increased electric risk (e.g. near boilers) must carry the "Safety" sign. However, the power source must not be located in such areas.

Risk of scalding from escaping coolant. Switch off cooling unit before disconnecting coolant flow or return lines.

Observe the information on the coolant safety data sheet when handling coolant. The coolant safety data sheet may be obtained from your service centre or downloaded from the manufacturer's website.

Use only suitable load-carrying equipment supplied by the manufacturer when transporting devices by crane.

- Hook chains and/or ropes onto all suspension points provided on the load-carrying equipment.
- Chains and ropes must be at the smallest angle possible to the vertical.
- Remove gas cylinder and wire-feed unit (MIG/MAG and TIG devices).

If the wire-feed unit is attached to a crane holder during welding, always use a suitable, insulated wirefeeder hoisting attachment (MIG/MAG and TIG devices).

If the device has a carrying strap or handle, this is intended solely for carrying by hand. The carrying strap is not to be used if transporting with a crane, counterbalanced lift truck or other mechanical hoist.

All lifting accessories (straps, handles, chains, etc.) used in connection with the device or its components must be tested regularly (e.g. for mechanical damage, corrosion or changes caused by other environmental factors).

The testing interval and scope of testing must comply with applicable national standards and directives as a minimum.

Odourless and colourless shielding gas may escape unnoticed if an adapter is used for the shielding gas connection. Prior to assembly, seal the device-side thread of the adapter for the shielding gas connection using suitable Teflon tape.

Requirement for the shielding gas

Especially with ring lines, contaminated shielding gas can cause damage to equipment and reduce welding quality.

Meet the following requirements regarding shielding gas quality:

- Solid particle size < 40 µm
 - Pressure condensation point < -20 °C
 - Max. oil content < 25 mg/m³
-

Use filters if necessary.

Danger from shielding gas cylinders

Shielding gas cylinders contain gas under pressure and can explode if damaged. As the shielding gas cylinders are part of the welding equipment, they must be handled with the greatest of care.

Protect shielding gas cylinders containing compressed gas from excessive heat, mechanical impact, slag, naked flames, sparks and arcs.

Mount the shielding gas cylinders vertically and secure according to instructions to prevent them falling over.

Keep the shielding gas cylinders well away from any welding or other electrical circuits.

Never hang a welding torch on a shielding gas cylinder.

Never touch a shielding gas cylinder with an electrode.

Risk of explosion - never attempt to weld a pressurised shielding gas cylinder.

Only use shielding gas cylinders suitable for the application in hand, along with the correct and appropriate accessories (regulator, hoses and fittings). Only use shielding gas cylinders and accessories that are in good condition.

Turn your face to one side when opening the valve of a shielding gas cylinder.

Close the shielding gas cylinder valve if no welding is taking place.

If the shielding gas cylinder is not connected, leave the valve cap in place on the cylinder.

The manufacturer's instructions must be observed as well as applicable national and international regulations for shielding gas cylinders and accessories.

Danger from escaping shielding gas

Risk of suffocation from the uncontrolled escape of shielding gas

Shielding gas is colourless and odourless and, in the event of a leak, can displace the oxygen in the ambient air.

- Ensure an adequate supply of fresh air with a ventilation rate of at least 20 m³/hour.
 - Observe safety and maintenance instructions on the shielding gas cylinder or the main gas supply.
 - Close the shielding gas cylinder valve or main gas supply if no welding is taking place.
 - Check the shielding gas cylinder or main gas supply for uncontrolled gas leakage before every start-up.
-

Safety measures at the installation location and during transport

A device toppling over could easily kill someone. Place the device on a solid, level surface such that it remains stable

- The maximum permissible tilt angle is 10°.
-

Special regulations apply in rooms at risk of fire or explosion

- Observe relevant national and international regulations.
-

Use internal directives and checks to ensure that the workplace environment is always clean and clearly laid out.

Only set up and operate the device in accordance with the degree of protection shown on the rating plate.

When setting up the device, ensure there is an all-round clearance of 0.5 m (1 ft. 7.69 in.) to ensure that cooling air can flow in and out freely.

When transporting the device, observe the relevant national and local guidelines and accident prevention regulations. This applies especially to guidelines regarding the risks arising during transport.

Do not lift or transport operational devices. Switch off devices before transport or lifting.

Before transporting the device, allow coolant to drain completely and detach the following components:

- Wirefeeder
 - Wirespool
 - Shielding gas cylinder
-

After transporting the device, the device must be visually inspected for damage before commissioning. Any damage must be repaired by trained service technicians before commissioning the device.

Safety measures in normal operation

Only operate the device when all safety devices are fully functional. If the safety devices are not fully functional, there is a risk of

- injury or death to the operator or a third party
 - damage to the device and other material assets belonging to the operator
 - inefficient operation of the device
-

Any safety devices that are not functioning properly must be repaired before switching on the device.

Never bypass or disable safety devices.

Before switching on the device, ensure that no one is likely to be endangered.

Check the device at least once a week for obvious damage and proper functioning of safety devices.

Always fasten the shielding gas cylinder securely and remove it beforehand if the device is to be transported by crane.

Only the manufacturer's original coolant is suitable for use with our devices due to its properties (electrical conductivity, anti-freeze agent, material compatibility, flammability, etc.).

Only use suitable original coolant from the manufacturer.

Do not mix the manufacturer's original coolant with other coolants.

Only connect the manufacturer's system components to the cooling circuit.

The manufacturer accepts no liability for damage resulting from use of other system components or a different coolant. In addition, all warranty claims will be forfeited.

Cooling Liquid FCL 10/20 does not ignite. The ethanol-based coolant can ignite under certain conditions. Transport the coolant only in its original, sealed containers and keep well away from any sources of ignition.

Used coolant must be disposed of properly in accordance with the relevant national and international regulations. The coolant safety data sheet may be obtained from your service centre or downloaded from the manufacturer's website.

Check the coolant level before starting to weld, while the system is still cool.

Commissioning, maintenance and repair

It is impossible to guarantee that bought-in parts are designed and manufactured to meet the demands made of them, or that they satisfy safety requirements.

- Use only original spare and wearing parts (also applies to standard parts).
 - Do not carry out any modifications, alterations, etc. to the device without the manufacturer's consent.
 - Components that are not in perfect condition must be replaced immediately.
 - When ordering, please give the exact designation and part number as shown in the spare parts list, as well as the serial number of your device.
-

The housing screws provide the ground conductor connection for earthing the housing parts.

Only use original housing screws in the correct number and tightened to the specified torque.

Safety inspection

The manufacturer recommends that a safety inspection of the device is performed at least once every 12 months.

The manufacturer recommends that the power source be calibrated during the same 12-month period.

A safety inspection should be carried out by a qualified electrician

- after any changes are made
 - after any additional parts are installed, or after any conversions
 - after repair, care and maintenance has been carried out
 - at least every twelve months.
-

For safety inspections, follow the appropriate national and international standards and directives.

Further details on safety inspection and calibration can be obtained from your service centre. They will provide you on request with any documents you may require.

Disposal

Do not dispose of this device with normal domestic waste! To comply with the European Directive on Waste Electrical and Electronic Equipment and its implementation as national law, electrical equipment that has reached the end of its life must be collected separately and returned to an approved recycling facility. Any device that you no longer require must either be returned to your dealer or given to one of the approved collection and recycling facilities in your area. Ignoring this European Directive may have potentially adverse effects on the environment and your health!

Safety symbols

Devices with the CE mark satisfy the essential requirements of the low-voltage and electromagnetic compatibility directives (e.g. relevant product standards of the EN 60 974 series).

Fronius International GmbH hereby declares that the device is compliant with Directive 2014/53/EU. The full text on the EU Declaration of Conformity can be found at the following address: <http://www.fronius.com>

Devices marked with the CSA test mark satisfy the requirements of the relevant standards for Canada and the USA.

Data protection

The user is responsible for the safekeeping of any changes made to the factory settings. The manufacturer accepts no liability for any deleted personal settings.

Copyright

Copyright of these operating instructions remains with the manufacturer.

The text and illustrations are all technically correct at the time of printing. We reserve the right to make changes. The contents of the operating instructions shall not provide the basis for any claims whatsoever on the part of the purchaser. If you have any suggestions for improvement, or can point out any mistakes that you have found in the instructions, we will be most grateful for your comments.

General information

Device concept

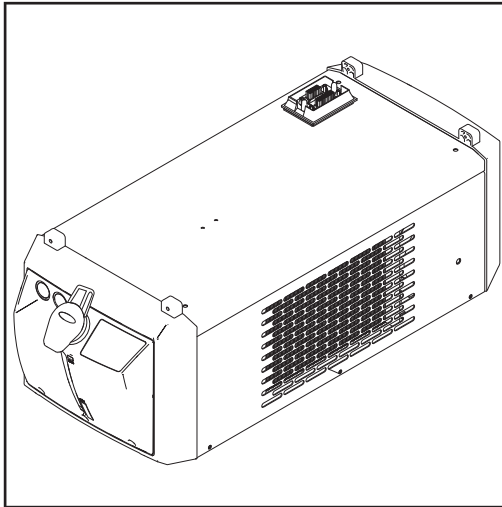

The cooling unit and the power source form a unit. As with the standalone power source, the power source/cooling unit combination can be mounted on the trolley.

Device versions

CU 1100i, CU 800i (standard version)

- For single-shift operation
- The coolant pump and fan are switched on and off automatically as standard. The operating status of the cooling unit can be manually changed by selecting different operating modes

CU 1100i /460 V, CU 800i /460 V (standard version for 460 V operation)

- For single-shift operation
- The coolant pump and fan are switched on and off automatically as standard. The operating status of the cooling unit can be manually changed by selecting different operating modes

CU 1100i /MV, CU 1100i /MV RVP (multivoltage version)

- For single-shift and multivoltage operation
- The coolant pump and fan are switched on and off automatically as standard. The operating status of the cooling unit can be manually changed by selecting different operating modes

CU 800i Pro (professional version)

- For multi-shift operation, multivoltage operation, 600 V operation
- The coolant pump and fan are switched on and off automatically as standard (if the OPT/i CU flow temperature sensor option has been selected, the coolant pump and fan are controlled electronically). The operating status of the cooling unit can be manually changed by selecting different operating modes

CU 1400i Pro (professional version)

- For multi-shift operation, multivoltage operation, 600 V operation
- The coolant pump and fan are switched on and off automatically as standard (if the OPT/i CU flow temperature sensor option has been selected, the coolant pump and fan are controlled electronically). The operating status of the cooling unit can be manually changed by selecting different operating modes.

To operate the cooling unit with the TPS 320i / 400i / 500i / 600i, TT 300i / 400i / 500i and MW 300i / 400i / 500i power sources, the OPT/i TPS 2. NT241 CU option 1400i must be fitted in the power sources.

CU 1400i Pro /MC (professional version)

- For multi-shift operation, multivoltage operation, 600 V operation
- The coolant pump and fan are controlled electronically as standard. The operating status of the cooling unit can be manually changed by selecting different operating modes.

To operate the cooling unit with the TPS 320i / 400i / 500i / 600i, TT 300i / 400i / 500i and MW 300i / 400i / 500i power sources, the OPT/i TPS 2. NT241 CU option 1400i must be fitted in the power sources.

Application area

The cooling unit can be used for:

- water-cooled MIG/MAG manual welding torches
- water-cooled MIG/MAG machine welding torches
- water-cooled MIG/MAG robot welding torches
- water-cooled TIG manual welding torches

Scope of supply

The scope of supply comprises:

- Cooling unit
- 5 l coolant in a canister
- Four 5x25 mm self-tapping screws
- Operating Instructions

Validity of "General Delivery and Payment Conditions"

With respect to cooling units, the "General Delivery and Payment Conditions" as stated in the price list only apply under the conditions listed below.

CU 800i, CU 800i /460 V, CU 1100i, CU 1100i /460 V, CU 1100i /MV, CU 1100i /MV RVP:

- max. 8 hrs operation per day (single-shift operation)
- only original Fronius coolant is used
- with regular maintenance and regular change of coolant

CU 800i Pro, CU 1400i Pro, CU 1400i Pro /MC:

- for multi-shift operation
- only original Fronius coolant is used
- with regular maintenance and regular change of coolant

Coolant pump service life in cooling units for single-shift operation

The following coolant pump service life figures apply to the following cooling units:

- CU 800i, 1100i
- CU 800i /460 V, 1100i /460 V
- CU 1100i /MV
- CU 1100i /MV RVP

If used properly, the coolant pump will have a service life of approx. 10,000 operating hours. After the end of its nominal service life, the coolant pump could develop a fault. To avoid a lengthy period of work disruption, the pump should be scheduled for replacement after approx. 10,000 operating hours.

Coolant pump service life in cooling units for multi-shift operation

The following coolant pump service life figures apply to the CU 1400i Pro /MC cooling unit.

If used properly, the coolant pump will have a service life of approx. 30,000 operating hours. After the end of its nominal service life, the coolant pump may develop a fault. To avoid a lengthy period of work disruption, the pump should be scheduled for replacement after approx. 30,000 operating hours.

The following coolant pump service life figures apply to the following cooling units:

- CU 800i Pro
- CU 1400i Pro

If used properly, the coolant pump will have a service life of approx. 20,000 operating hours. After the end of its nominal service life, the coolant pump may develop a fault. To avoid a lengthy period of work disruption, the pump should be scheduled for replacement after approx. 20,000 operating hours.

General

As a result of firmware updates, you may find that your device has certain functions that are not described in these operating instructions, or vice versa. Certain illustrations may also differ slightly from the actual controls on your device, but these controls function in exactly the same way.

Information about the coolant**CAUTION!****Danger from using non-permitted coolant.**

This can result in serious damage to property.

- ▶ Only use coolant available from the manufacturer.
 - ▶ Do not mix different coolants.
 - ▶ When changing the coolant, make sure all the coolant is replaced.
 - ▶ When switching from ethanol-based coolant to FCL 10 coolant, Change Kit FCL10 must be used and the instructions provided must be followed.
-

Information on leaks

The following information on leaks does not apply to the CU 800i Pro, CU 1400i Pro and the CU 1400i Pro/MC.

The shaft sealing surfaces inside the coolant pump are lubricated by the coolant, meaning that a certain leakage flow should always be expected. A low leakage flow is permitted.

The coolant pump requires a certain warm-up time after being started for the first time or upon restarting after a long period of downtime. An increased leakage flow can occur during this warm-up phase. The leakage flow will normally sink back down to a low level after the warm-up phase. If this is not the case then contact After-Sales Service.

Warning notices on the device

The cooling unit displays safety symbols and has a rating plate. The rating plate and safety symbols must not be removed or painted over. The symbols warn against operating the equipment incorrectly, as this could result in serious injury or damage to property.

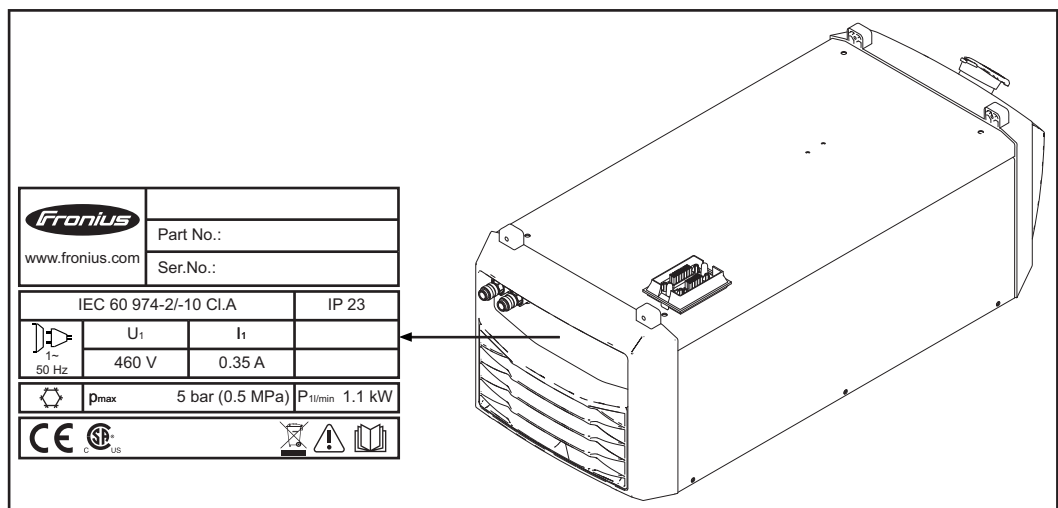

Welding is dangerous. The following basic requirements must be met to ensure the equipment is used properly:

- Welders must be sufficiently qualified
- Suitable protective equipment must be used
- All persons not involved must be kept at a safe distance from the cooling unit and the welding process



Do not use the functions described here until you have fully read and understood the following documents:

- This document
- All documents relating to the system components, especially the safety rules



Do not dispose of used devices with domestic waste. Dispose of them according to the safety rules.

Options

OPT/i CU flow temperature sensor

The OPT/i CU flow temperature sensor option offers monitoring of the coolant temperature and flow rate. This option is available with the following devices:

- CU 800i, 1100i
- CU 800i /460 V, 1100i /460 V
- CU 1100i /MV
- CU 800i Pro, 1400i Pro

The option is included as standard on the CU 1100i /MC RVP and CU 1400i Pro/MC cooling unit.

Coolant temperature monitoring and flow monitoring are parts of an installation set and cannot be ordered separately.

Coolant temperature monitoring

A temperature sensor monitors the coolant return temperature during welding.

How it works:

- If the temperature of the coolant reaches 68°C (154.4°F)
 - the power source outputs a warning
 - the welding current is not interrupted
 - the cooling unit remains operational
- If the temperature of the coolant exceeds 70°C (158°F)
 - the power source outputs an error message
 - the temperature sensor interrupts the welding current
 - the cooling unit remains operational
- The temperature sensor restores the welding current when the coolant temperature falls to 65°C (149°F)

Flow monitoring

A flow sensor monitors the coolant flow during welding.

How it works:

- If the coolant flow falls to between 1 and 0.7 l/min (0.26 - 0.18 gal./min)
 - the power source outputs a warning
 - the welding current is not interrupted
 - the cooling unit remains operational
 - If the coolant flow drops below 0.7 l/min (0.18 gal./min)
 - the power source outputs an error message
 - the flow rate monitor interrupts the welding current
 - the cooling unit is switched off
-

OPT CU coolant filter

This option is available for all cooling units in the CU series.

The coolant filter is equipped with a CrNi screen; its function is to filter dirt particles above 100 micrometres in size from the coolant. This ensures that no coarse dirt particles can pass into the coolant circuit. The coolant filter is fitted to the coolant return connection on the cooling unit.

The option is included as standard on the CU 1100i /MV RVP cooling unit.

OPT/i CU level sensor

This option is available with the following devices:

- CU 800i, 1100i
- CU 800i /460 V, 1100i /460 V
- CU 1100i /MV
- CU 1100i /MV RVP
- CU 800i Pro, 1400i Pro

The option is included as standard on the CU 1400i Pro/MC cooling unit.

The level sensor monitors the level of coolant in the cooling unit.

If both the OPT/i CU flow temperature sensor and the OPT/i CU level sensor options are installed in the cooling unit, the level sensor works as follows:

- If the coolant drops below the minimum level:
 - the power source outputs a warning
 - the welding current is not interrupted
 - the cooling unit remains operational

If just the OPT/i CU level sensor option is installed in the cooling unit, the level sensor works as follows:

- If the coolant drops below the minimum level:
 - the power source outputs an error message
 - the level sensor interrupts the welding current
 - the cooling unit is switched off

OPT CU front coolant connections

This option is available for the following devices:

- CU 1100i
- CU 1100i /460 V
- CU 1100i /MV
- CU 1100i /MV RVP
- CU 1400i Pro
- CU 1400i Pro /MC

When the front coolant connection option is fitted, the cooling unit can be operated with the following power sources:

- TPS 320i C
- TransTig 300i - 500i
- MagicWave 300i - 500i

OPT/i CU Torch deflate

Function for emptying / filling the torch hosepack, e.g. when changing the torch body
The power source does not have to be switched off during this process.

This option is available for the following devices:

- CU 1100i
- CU 1100i /460 V
- CU 1100i /MV
- CU 1100i /MV RVP
- CU 1400i Pro
- CU 1400i Pro /MC

To operate the OPT/i CU Torch deflate option, the OPT/i CU flow temperature sensor option must be fitted on the cooling unit.

Connections and mechanical components

Connections and mechanical components

Connections and mechanical components: CU 1100i, CU 1100i /460V, CU 1100i /MV, CU 1100i /MV RVP, CU 1400i Pro, CU 1400i Pro /MC

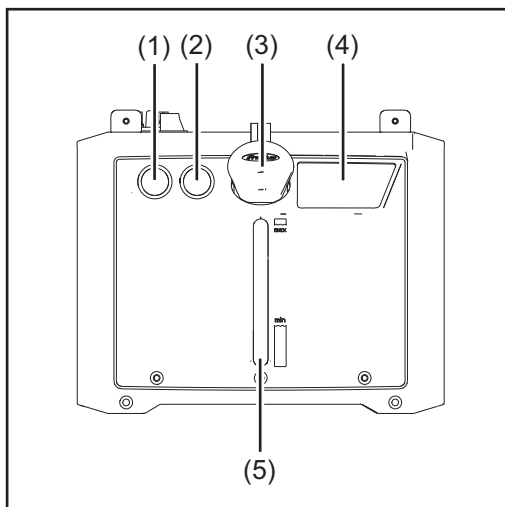

Front of cooling unit

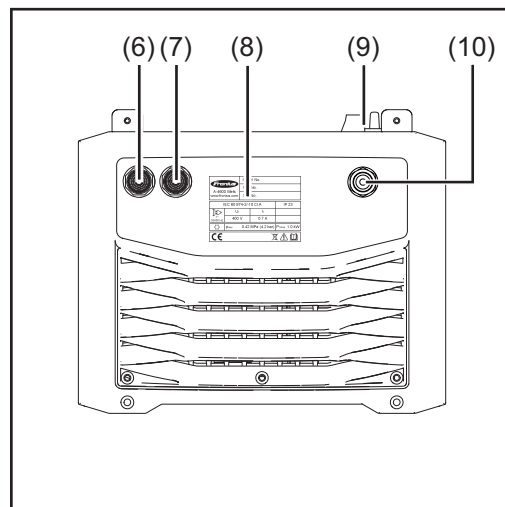

Rear of cooling unit

No.	Function
(1)	Coolant flow connection blanking cover (blue)
(2)	Coolant return connection blanking cover (red)
(3)	Screw cap for coolant container
(4)	Information on maintenance and operation
(5)	Coolant viewing window
(6)	Coolant return connection (red)
(7)	Coolant flow connection (blue)
(8)	Rating plate
(9)	Power source connection
(10)	Gas connection max. 20 l/min. Gas flow rate on the pressure regulator max. 4 bar

Connections and mechanical components: CU 800i, CU 800i /460 V, CU 800i Pro

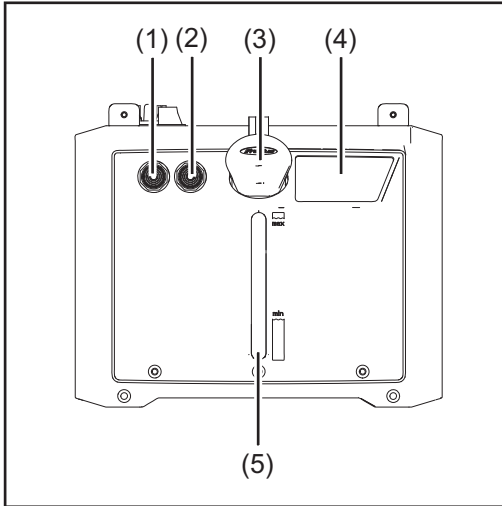

Front of cooling unit

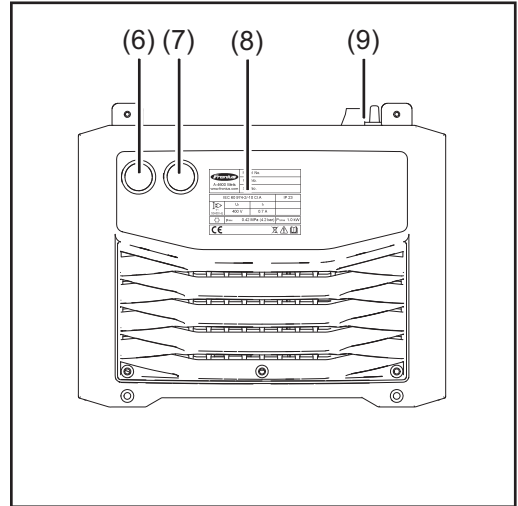

Rear of cooling unit

No.	Function
(1)	Coolant flow connection (blue)
(2)	Coolant return connection (red)
(3)	Screw cap for coolant container
(4)	Information on maintenance and operation
(5)	Coolant viewing window
(6)	Blanking cover
(7)	Blanking cover
(8)	Rating plate
(9)	Power source connection

Installation and commissioning

Before installation and commissioning

Safety

WARNING!

Danger due to incorrect operation and incorrectly performed work.

This can result in severe personal injury and damage to property.

- ▶ All the work and functions described in this document must only be carried out and used by trained and qualified personnel.
- ▶ Fully read and understand this document.
- ▶ Fully read and understand all the Operating Instructions for the system components, especially the safety rules.

Setup regulations

WARNING!

Danger from machines falling or toppling over.

This can result in serious injury and damage to property.

- ▶ Place all system components on a solid, level surface in such a way that they remain stable.

WARNING!

Danger from electric current.

An electric shock can be fatal.

- ▶ Ensure the cooling unit is properly insulated.
- ▶ Always ensure that there is no electrically conductive connection between the base plate of the cooling unit and the surface.
- ▶ Before installing the cooling unit, remove all electrically conductive parts between the base plate of the cooling unit and the surface.

The device is tested to IP 23 protection, meaning:

- Protection against penetration by solid foreign bodies with diameters > 12.5 mm (0.49 in.)
- Protection against spraywater at any angle up to 60° to the vertical

Cooling air

The system must be set up in such a way that the cooling air can flow unimpeded through the slots in the side panels. Ensure that there is always an all-round clearance of 0.5 m (1 ft 7.69 in.) around the device.

CAUTION!

Risk from insufficient cooling air supply.

This can result in serious damage to property.

- ▶ Air inlets and outlets must never be covered, not even partially.

Dust

Ensure that any metallic dust, for example from grinding work, is not sucked into the system by the fan.

Outdoor operation

The device can be set up and operated outdoors in accordance with degree of protection IP23. Avoid direct wetting (e.g. from rain).

Information about the coolant

The cooling unit is delivered empty.

Use only original Fronius coolant (Cooling Liquid FCL 10/20 or torch coolant) when filling the cooling unit. Other coolants are not recommended for electrical conductivity and material compatibility reasons.

Guarantee provisions regarding the coolant pump

The coolant pump may only be used with original coolant supplied by the manufacturer. Do not allow the coolant pump to run dry (even for a very short time), as this will destroy the coolant pump. The manufacturer accepts no liability for damage caused in such cases.

Proper use

The device is intended solely for use in conjunction with Fronius system components.

The device is to be used exclusively for its intended purpose.

Any use above and beyond this purpose is deemed improper. The manufacturer is not liable for any damage, or unexpected or incorrect results arising out of such misuse.

Proper use also includes:

- carefully reading these operating instructions
- following all the instructions and safety rules in these operating instructions
- performing all stipulated inspection and maintenance work

The device is designed for use in industry and the workshop. The manufacturer accepts no responsibility for any damage caused through use in a domestic setting.

Fitting the cooling unit to the trolley

General

The welding system can be fitted to a trolley to make the system (incl. cooling unit) more mobile.

CAUTION!

Risk due to work that has been carried out incorrectly.

This can result in serious damage to property

- ▶ If the welding system is not equipped with an auto-transformer, the cooling unit must be installed right at the bottom.

Fitting the cooling unit to trolley

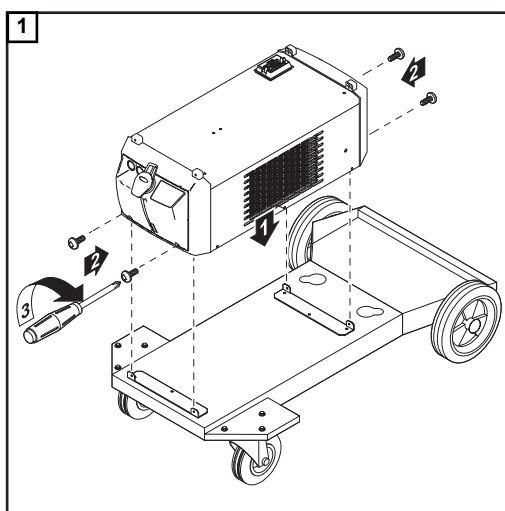

CAUTION!

Risk due to work that has been carried out incorrectly.

This can result in serious damage to property

- ▶ Please see the respective trolley Operating Instructions and Installation Instructions for more information about the trolley.

NOTE!

Screws are supplied with the trolley.

Connecting the cooling unit to the power source

Safety

WARNING!

Danger from electric current.

An electric shock can be fatal.

- ▶ Turn the power source mains switch to the "O" position.
- ▶ Disconnect the power source from the mains.
- ▶ Ensure that the power source remains disconnected from the mains until all work has been completed.

Connecting the cooling unit to the power source

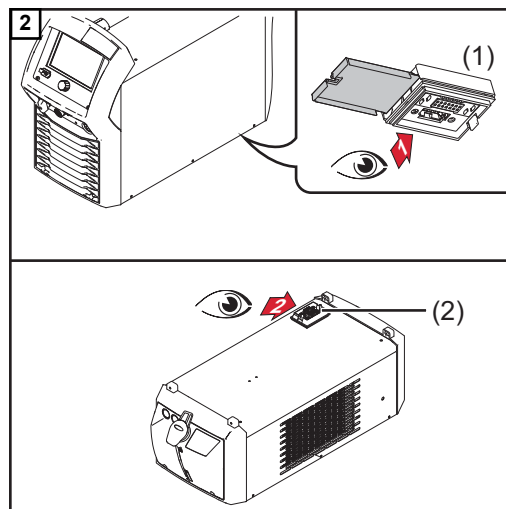
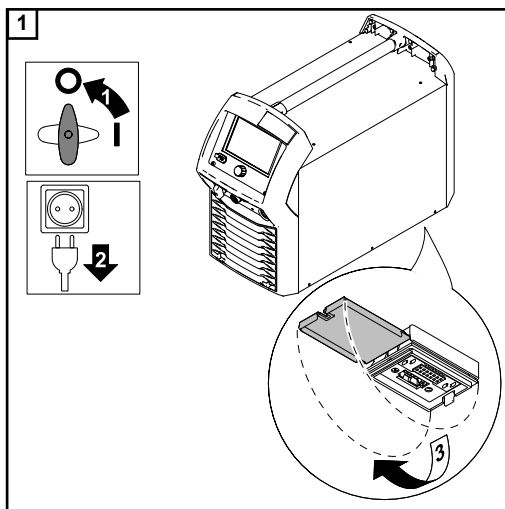

Ensure that the cooling unit connection (1) and the power source connection (2) are clean and undamaged

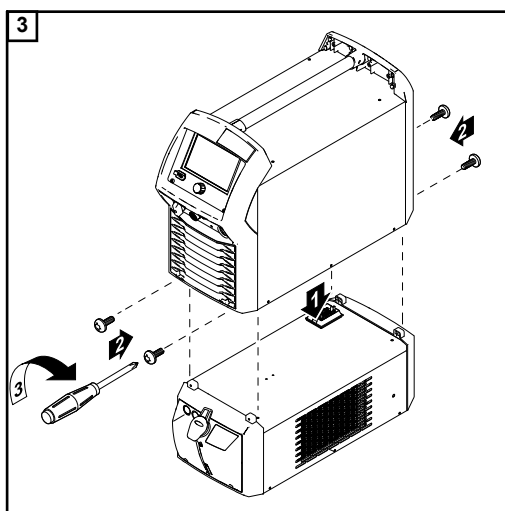

NOTE!

Screws are supplied with the cooling unit.

Only with OPT/i CU Torch deflate option on the cooling unit:

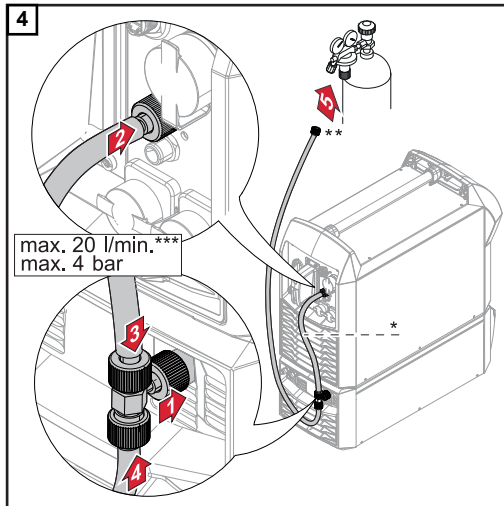

- * Gas hose in cooling unit scope of supply
- ** For gas supply
- *** Max. 20 l/min. gas flow rate on the pressure regulator/max. 4 bar

Connect the coolant hoses to the cooling unit

Safety

WARNING!

Danger from electric current.

An electric shock can be fatal.

- ▶ Turn the power source mains switch to the "O" position.
- ▶ Disconnect the power source from the mains.
- ▶ Ensure that the power source remains disconnected from the mains until all work has been completed.

Connecting the interconnecting hosepack coolant hoses to the cooling unit

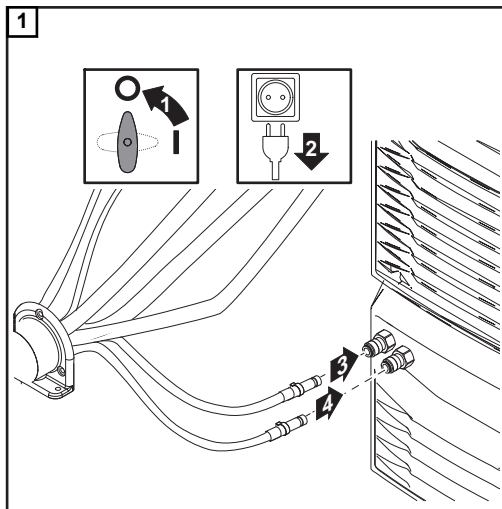

NOTE!

Use the colour codes to connect the coolant hoses to the appropriate coolant flow and return connections on the cooling unit.

TPS 270i C, TPS 320i C, TT 300i - 500i, MW 300i - 500i: connecting the welding torch coolant hoses to the cooling unit

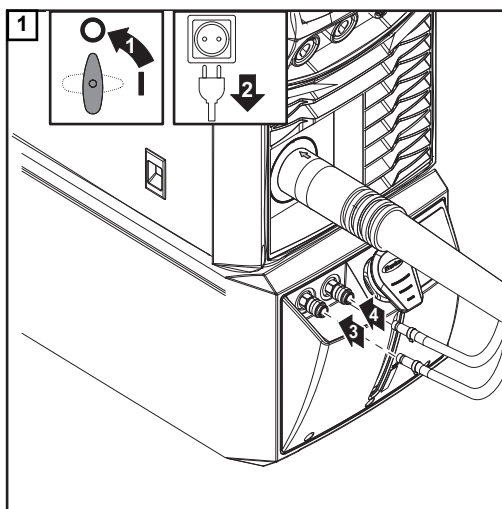

NOTE!

Use the colour codes to connect the coolant hoses to the appropriate coolant flow and return connections on the cooling unit.

NOTE!

If a TPS 270i C power source is used with a CU 800i Pro cooling unit, the cooling unit will not benefit from the maximum pump power.

NOTE!

If a TPS 320i C power source is used with a CU 1400i Pro or CU 1400i Pro /MC cooling unit, the cooling unit will not benefit from the maximum pump power.

Filling and starting up the cooling unit

Filling the cooling unit

WARNING!

Danger from electric current.

An electric shock can be fatal.

- ▶ Turn the power source mains switch to the "O" position.
- ▶ Disconnect the power source from the mains.
- ▶ Ensure that the power source remains disconnected from the mains until all work has been completed.

CAUTION!

Risk from coolant leakage

This can result in serious damage to property.

- ▶ If there is any coolant on the exterior of the cooling unit, remove it immediately.
- ▶ Make sure that no coolant gets into the device.

CAUTION!

Risk due to work that has been carried out incorrectly

This can result in serious damage to property.

- ▶ If the coolant connections are on the front of the cooling unit, carry out the following steps as shown – but at the front coolant flow connection (blue).

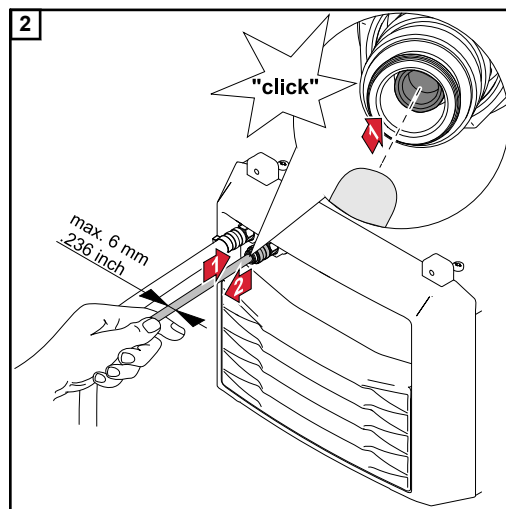
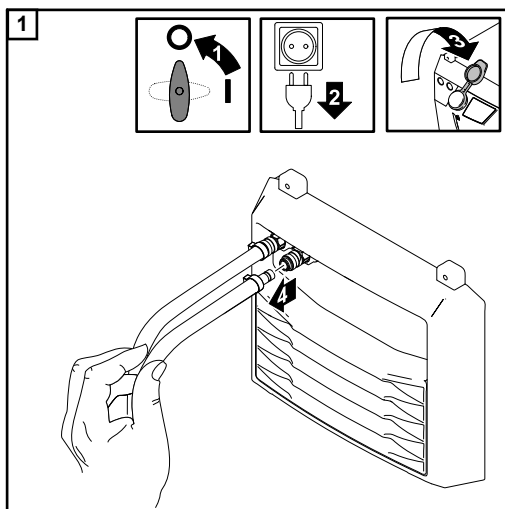

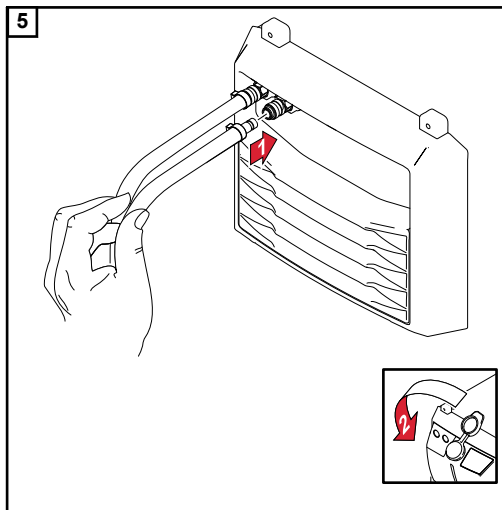
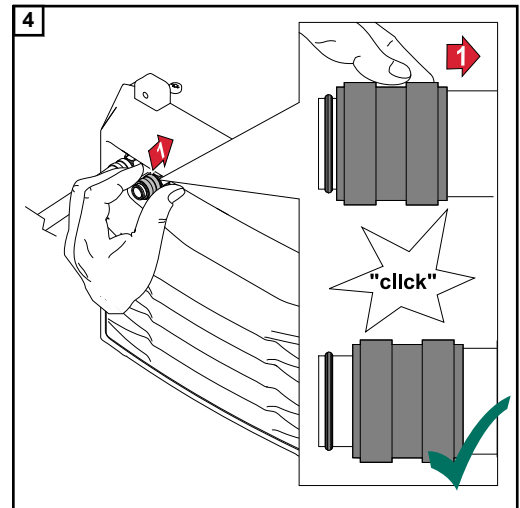
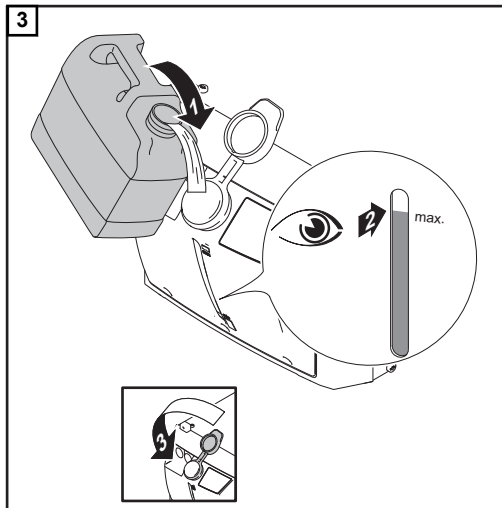

Starting up the cooling unit

CAUTION!

Risk from insufficient coolant in the cooling unit.

This can result in serious damage to property.

- ▶ Before starting up the cooling unit, first check that it contains an adequate amount of coolant and that the coolant is clean and uncontaminated.

CAUTION!

Risk from inadequate coolant flow.

This can result in serious damage to property.

- ▶ During welding, check the coolant flow at regular intervals.
- ▶ You should be able to see a steady return flow of coolant to the coolant container.

The cooling unit is powered and controlled by the power source. If the power source mains switch is turned to position "I", the cooling unit will start to operate as described below.

CU 800i, CU 800i /460 V, CU 800i Pro, CU 1100i, CU 1100i /460 V, CU 1100i /MV, CU 1100i /MV RVP, CU 1400i Pro, CU 1400i Pro /MC:

- the fans run for approx. 5 seconds
- the coolant pump runs for approx. 3 minutes. The coolant pump switches off again if welding does not start after around 3 minutes

The operating status of the cooling unit can be manually changed by selecting different operating modes.

⚠ CAUTION!

Risk from insufficient coolant when using the cooling unit for the first time.

This can result in serious damage to property.

- ▶ If the cooling unit is fitted with an OPT/i CU level sensor, the OPT/i CU level sensor may cause an error message to be output if long hosepacks are being used when starting for the first time.
- ▶ If this happens, top up the coolant.

OPT/i CU Torch deflate: Emptying/filling the torch hosepack

When using OPT/i CU Torch deflate option, the "Empty/fill torch hosepack" setup parameter is available in the power source setup menu under the component settings for the AUT and ECO operating modes.

This function can be used to return the coolant in the torch hosepack to the coolant tank, for example when changing the torch body.

The power source does not have to be turned off during this process.

NOTE!

When emptying long hosepacks > 8 m, there is a risk of a completely full coolant tank overflowing - slipping hazard!

If the coolant temperature is < 50 °C, the emptying process is started from the power source setup menu or the welding torch and takes a maximum of 60 seconds.

After the torch body has been successfully changed, the torch hosepack can be filled with coolant.

Procedure for filling long torch hosepacks (> 8 m, extension hosepacks):

- 1 Connect the hosepack/extension hosepack to the power source
- 2 Fill the coolant tank to the maximum
- 3 Fill the hosepack with coolant
- 4 Do not top up the coolant tank, otherwise the tank could overflow when the torch hosepack is emptied.

More in-depth information about emptying/filling the torch hosepack can be found in the Operating Instructions for the power source or welding torch.

Operating modes **The individual operating modes can be selected on the power source.**

on

Available on:

CU 800i, CU 800i /460 V, CU 800i Pro, CU 1100i, CU 1100i /460 V, CU 1100i /MV, CU 1100i /MV RVP, CU 1400i Pro, CU 1400i Pro /MC

Operating status:

Continuous. The cooling units starts running as soon as the power source is switched on (fan and coolant pump permanently running)

off

Available on:

CU 800i, CU 800i /460 V, CU 800i Pro, CU 1100i, CU 1100i /460 V, CU 1100i /MV, CU 1100i /MV RVP, CU 1400i Pro, CU 1400i Pro /MC

Operating status:

Inoperative, even when welding starts.

auto

(factory setting)

Available on:

CU 800i, CU 800i /460 V, CU 800i Pro, CU 1100i, CU 1100i /460 V, CU 1100i /MV, CU 1100i /MV RVP, CU 1400i Pro, CU 1400i Pro /MC

Operating status:

The cooling unit begins to run as soon as welding starts (fan and coolant pump run). At the end of welding, the cooling unit continues to run for another 2 minutes. The cooling unit switches off after these 2 minutes.

eco

Available on:

CU 1400i Pro /MC, CU 1400i Pro (only with OPT/i CU flow temperature sensor option fitted)

Operating status:

The coolant pump starts to run when welding starts and is electronically controlled subject to the coolant return temperature. The fans start up at a coolant return temperature of 40 °C (104 °F) and are electronically controlled subject to the return temperature. After the end of welding, the coolant pump and fans continue to run for another 2 minutes subject to the coolant return temperature. After these 2 minutes have passed, the fans and coolant pump are switched off.

Recommended application of the operating modes

on
for high performance welding (maximum cooling capacity)

- eco**
for energy-efficient cooling
- longer service life of the coolant pump
 - less soiling of the cooler in the cooling unit
 - lower noise emissions
 - reduced power consumption
-

Disconnect the cooling unit from the power source

Safety

WARNING!

Danger from electric current.

An electric shock can be fatal.

- ▶ Turn the power source mains switch to the "O" position.
- ▶ Disconnect the power source from the mains.
- ▶ Ensure that the power source remains disconnected from the mains until all work has been completed.

CAUTION!

Danger from hot coolant.

This can result in severe scalds.

- ▶ Wait until the coolant has cooled down before carrying out any of the activities described below.

Disconnecting the cooling unit from the power source

CAUTION!

Risk from coolant leakage.

This can result in serious damage to property.

- ▶ Make sure that no coolant gets into the device.
- ▶ If coolant leaks out, remove it immediately.

1 Disconnect the coolant hoses from the cooling unit

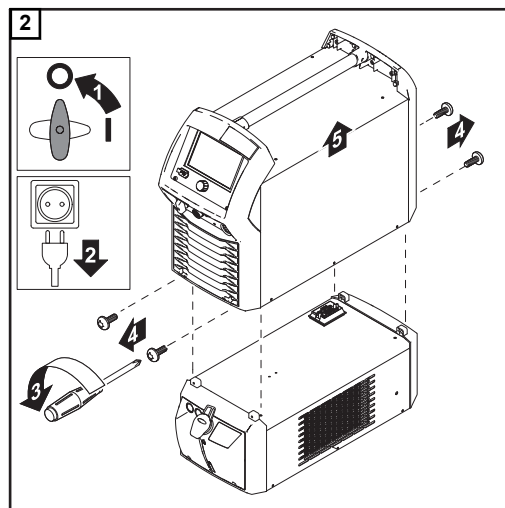

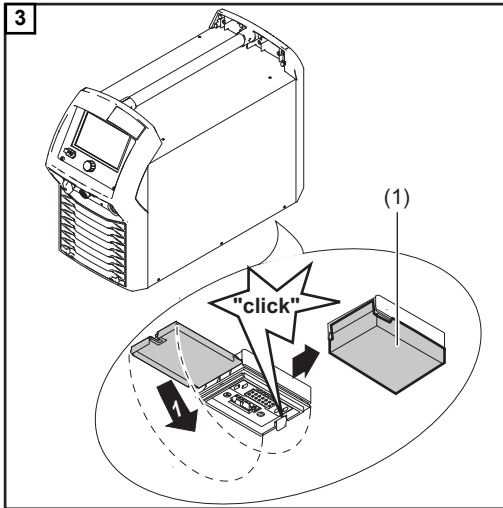

⚠ CAUTION!

Danger from short circuits.

This can result in serious injury and damage to property.

- ▶ Dirt and damage can cause short circuits on the cooling unit connection.
- ▶ After dismantling the power source, always close the cooling unit connection cover (1) on the underside of the power source.

Fitting the coolant filter option

Safety

WARNING!

Danger from electric current.

An electric shock can be fatal.

- ▶ Turn the power source mains switch to the "O" position.
- ▶ Disconnect the power source from the mains.
- ▶ Ensure that the power source remains disconnected from the mains until all work has been completed.

CAUTION!

Danger from hot coolant.

This can result in severe scalds.

- ▶ Wait until the coolant has cooled down before carrying out any of the activities described below.

Fitting the coolant filter option

CAUTION!

Risk from coolant leakage.

This can result in serious damage to property.

- ▶ Make sure that no coolant gets into the device.
- ▶ If coolant leaks out, remove it immediately.

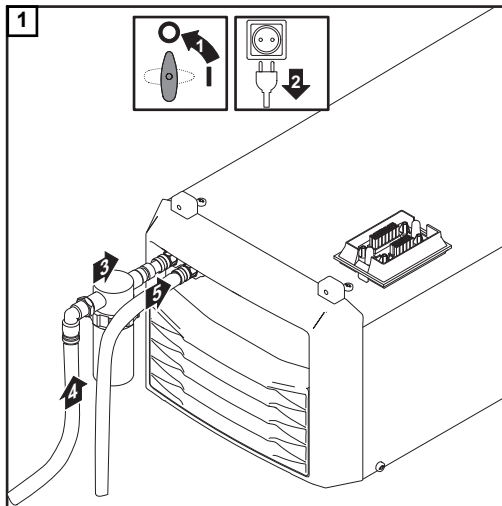

CAUTION!

Risk due to work that has been carried out incorrectly.

This can result in serious damage to property.

- ▶ If the coolant connections are on the front of the cooling unit, fit the coolant filter in the same way.
- ▶ Connect the coolant filter to the coolant return connection (red) on the front of the cooling unit.

Troubleshooting

Troubleshooting

Safety

WARNING!

Danger due to work that has been carried out incorrectly.

This can result in serious injury and damage to property.

- ▶ All the work described below must only be carried out by trained and qualified personnel.
- ▶ Fully read and understand this document.
- ▶ Fully read and understand all the Operating Instructions for the system components, especially the safety rules.

WARNING!

Danger from electric current.

An electric shock can be fatal.

- ▶ Turn the power source mains switch to the "O" position.
- ▶ Disconnect the power source from the mains.
- ▶ Ensure that the power source remains disconnected from the mains until all work has been completed.
- ▶ After opening the device, use a suitable measuring instrument to check that electrically charged components (e.g. capacitors) have been discharged.

WARNING!

Danger from inadequate ground conductor connections.

This can result in serious injury and damage to property.

- ▶ The housing screws provide a suitable ground conductor connection for earthing the housing and must NOT be replaced by any other screws that do not provide a reliable ground conductor connection.

CAUTION!

Danger from hot coolant.

This can result in severe scalds.

- ▶ Wait until the coolant has cooled down before carrying out any of the activities described below.

CAUTION!

Risk from coolant leakage.

This can result in serious damage to property.

- ▶ Make sure that no coolant gets into the device.
- ▶ If there is any coolant on the exterior of the cooling unit, remove it immediately.

Troubleshooting

Make a note of the serial number and configuration of the device and contact our After-Sales Service team with a detailed description of the error, if

- errors occur that are not listed below
- the troubleshooting measures listed are unsuccessful

Insufficient or no coolant flow

Cause: Coolant level too low

Remedy: Top up coolant

Cause: Constriction or foreign body in cooling circuit

Remedy: Remove constriction or foreign body

Cause: Coolant contaminated

Remedy: Change the coolant and then bleed the cooling unit

Cause: Coolant filter (option) misplaced when connecting coolant return

Remedy: Clean coolant filter using clean tap water or change filter element

Cause: Coolant pump defective

Remedy: Contact After-Sales Service

With CU 800i, CU 1100i, CU 1100i /MV: Insufficient or no coolant flow

Cause: Coolant pump sticking

Remedy: Turn the coolant pump shaft (see operating instructions, section "Turning the coolant pump shaft on the CU 800i, CU 1100i, CU 1100i /MV"). Contact After-Sales Service if the coolant pump shaft proves impossible to turn

With CU 800i, CU 1100i, CU 1100i /MV: Coolant pump does not work after turning the coolant pump shaft

Cause: Temperature switch on coolant pump has tripped

Remedy: Wait until the end of the coolant pump's cooling phase (2 - 3 minutes)

With CU 800i Pro, CU 1100i /460 V, CU 1100i /MV RVP, CU 1400i Pro, CU 1400i Pro /MC: Insufficient or no coolant flow

Cause: Coolant pump sticking

Remedy: Contact After-Sales Service

Insufficient cooling power

Cause: Cooler contaminated

Remedy: Gas purge cooler with dry compressed air

Cause: Faulty fan

Remedy: Contact After-Sales Service

Cause: Coolant pump defective

Remedy: Contact After-Sales Service

High operating noise level

Cause: Coolant level too low

Remedy: Top up coolant

Cause: Coolant pump defective

Remedy: Contact After-Sales Service

With CU 800i, CU 1100i, CU 1100i /MV: The welding torch becomes very hot

Cause: The specification of the cooling unit is inadequate

Remedy: Observe the duty cycle and loading limits

Cause: The specification of the welding torch is inadequate

Remedy: Observe the duty cycle and loading limits

Cause: Inadequate coolant flow

Remedy: Check coolant level. Top up with coolant if necessary
Check coolant for contamination. Change the coolant if necessary

Cause: Inadequate coolant flow

Remedy: Coolant pump sticking: Turn the coolant pump shaft (see operating instructions, section "Turning the coolant pump shaft on the CU 800i, CU 1100i, CU 1100i /MV"). Contact After-Sales Service if the coolant pump shaft proves impossible to turn

With CU 800i /460 V, CU 800i Pro, CU 1100i /460 V, CU 1100i /MV RVP, CU 1400i Pro, CU 1400i Pro /MC: The welding torch becomes very hot

Cause: The specification of the cooling unit is inadequate

Remedy: Observe the duty cycle and loading limits

Cause: The specification of the welding torch is inadequate

Remedy: Observe the duty cycle and loading limits

Cause: Inadequate coolant flow

Remedy: Check coolant level. Top up with coolant if necessary
Check coolant for contamination. Change the coolant if necessary

Cause: Inadequate coolant flow

Remedy: Coolant pump sticking: Contact After-Sales Service

Turning the coolant pump shaft on the CU 800i, CU 1100i, CU 1100i /MV

Safety

WARNING!

Danger due to work that has been carried out incorrectly.

This can result in severe personal injury and damage to property

- ▶ All the work described below must only be carried out by trained and qualified personnel.
- ▶ Fully read and understand this document.
- ▶ Fully read and understand all the Operating Instructions for the system components, especially the safety rules.

WARNING!

Danger from electric current.

An electric shock can be fatal.

- ▶ Turn the power source mains switch to the "O" position.
- ▶ Disconnect the power source from the mains.
- ▶ Ensure that the power source remains disconnected from the mains until all work has been completed.

Turning the coolant pump shaft

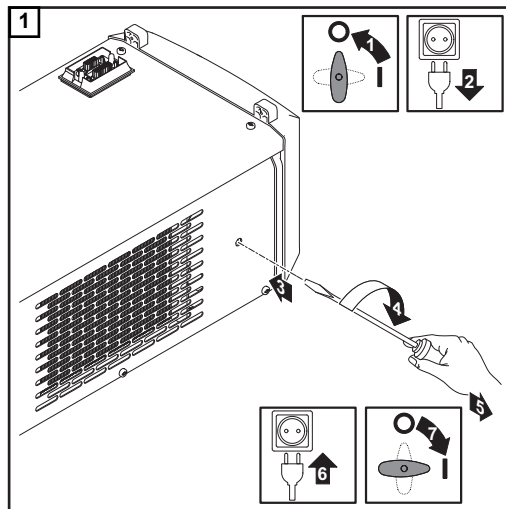

Care, maintenance and disposal

Care, maintenance and disposal

Safety



WARNING!

Danger due to work that has been carried out incorrectly.

All the work described below must only be carried out by trained and qualified personnel.

- ▶ Fully read and understand this document.
- ▶ Fully read and understand all the Operating Instructions for the system components, especially the safety rules.



WARNING!

Danger from electric current.

An electric shock can be fatal.

- ▶ Turn the power source mains switch to the "O" position.
- ▶ Disconnect the power source from the mains.
- ▶ Ensure that the power source remains disconnected from the mains until all work has been completed.
- ▶ After opening the device, use a suitable measuring instrument to check that electrically charged components (e.g. capacitors) have been discharged.



WARNING!

Danger from inadequate ground conductor connection.

This can result in serious injury and damage to property.

- ▶ The housing screws provide a suitable ground conductor connection for earthing the housing and must NOT be replaced by any other screws that do not provide a reliable ground conductor connection.



CAUTION!

Danger from hot coolant.

This can result in severe scalds.

- ▶ Wait until the coolant has cooled down before carrying out any of the activities described below.



CAUTION!

Risk from coolant leakage.

This can result in serious damage to property.

- ▶ Make sure that no coolant gets into the device.
- ▶ If there is any coolant on the exterior of the cooling unit, remove it immediately.

General

Under normal operating conditions, the device requires only a minimum of care and maintenance. However, it is vital to observe some important points to ensure the welding system remains in a usable condition for many years.

Symbols for care and maintenance of the cooling unit

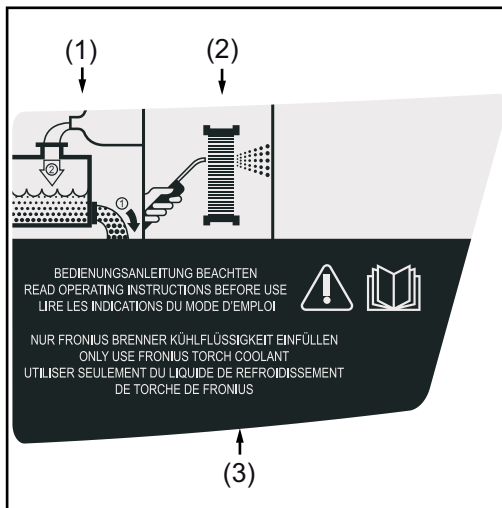

- (1) Changing the coolant
- (2) Gas purging the cooler
- (3) Read operating instructions

The relevant maintenance intervals and maintenance work are described in detail over the following pages.

Maintenance intervals, maintenance work

At every start-up

⚠ CAUTION!

Risk due to start-up without coolant.

This can result in serious damage to property.

- ▶ If water-cooled system components are operated without coolant, this will normally result in the failure of the system components. Fronius shall not be liable for any damage resulting from such action. In addition, no warranty claims will be entertained.

- Ensure that all the hosepacks, the welding torch and the ground earth connection are undamaged
- Check that there is an all-round clearance of 0.5 m (1 ft 7.69 in.) to ensure that cooling air can flow in and out freely
- Check the screw connections between all system components for tightness
- Check all the coolant connections of the welding system for tightness
- Monitor the coolant return flow in the coolant container
 - If no coolant is returning to the container, identify and remedy the cause

Once a week

- Check coolant level. If the coolant level is below the "min" mark, top up with coolant
- Check the purity of the coolant. Change the coolant if necessary

⚠ CAUTION!

Risk from non-permitted coolant.

This can result in serious damage to property.

- ▶ Use only original Fronius coolant (Cooling Liquid FCL 10/20 or torch coolant) when filling the cooling unit.
- ▶ Other coolants are not recommended for electrical conductivity and material compatibility reasons.

Every 2 months

- If present: Check the coolant filter for dirt and clean if necessary

Every 6 months

- Gas purge the cooler

Every 6 months in 3-shift operation with ethanol-based coolant

- Gas purge the cooler
- Change the coolant

Every 12 months in single-shift operation with ethanol-based coolant

- Change the ethanol-based coolant

Every 12 months in 3-shift operation with FCL 10/20 coolant

- Change the coolant

Every 24 months in single-shift operation with FCL 10/20 coolant

- Change the coolant

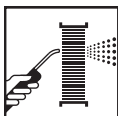
Gas purging the cooler**⚠ CAUTION!****Risk from gas purging the cooler.**

This may result in damage to electronic components.

- ▶ Always follow the instructions in the "Safety" section at the start of the "Care, maintenance and disposal" chapter.
- ▶ Do not bring the air nozzle too close to electronic components.

For the sake of clarity, the cooling unit is shown in the following figures without the power source. However, the power source can remain on the cooling unit when gas purging the cooler.

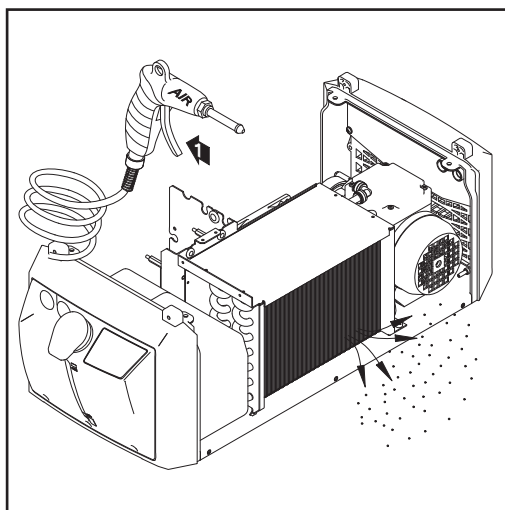

- Remove the device side panels and clean the cooler

If a large amount of dust has accumulated:

- remove device side panels and clean inside of device with dry, reduced compressed air.

Change the coolant



⚠ CAUTION!

Danger from welding current and accidental ignition of an arc.

This can result in serious injury and damage to property.

- ▶ Disconnect the ground earth connection between the welding system and the work-piece.
- ▶ Remove the wire electrode from the welding torch being used.
- ▶ Depending on the system, remove the wirespool or the basket-type spool from the power source or the wirefeeder.

NOTE!

To avoid environmental pollution due to improper coolant disposal:

- ▶ The coolant must not be disposed of in the public sewage system.
- ▶ Dispose of coolant in accordance with the applicable local and national regulations.

⚠ CAUTION!

Risk from using a non-permitted coolant.

This can result in serious damage to property.

- ▶ Use only original Fronius coolant (Cooling Liquid FCL 10/20 or torch coolant) when refilling the cooling unit.

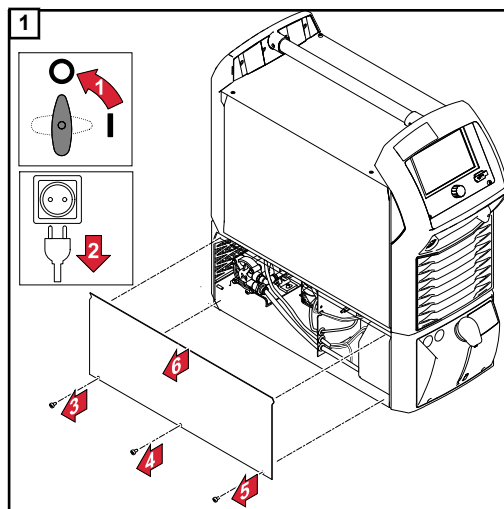

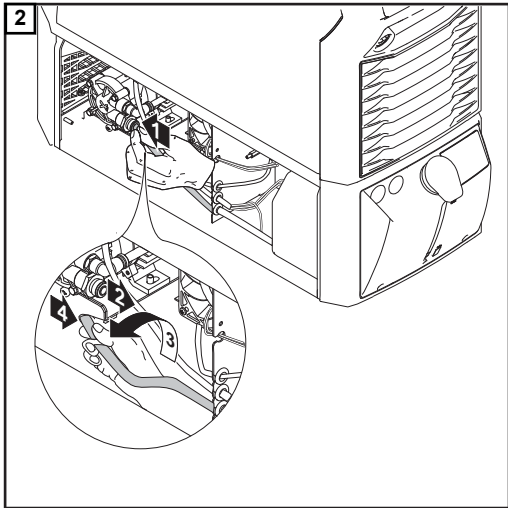

⚠ CAUTION!

Risk from coolant leakage.
This can result in serious damage to property.

- ▶ Seal off the coolant hose as soon as it is pulled out of the coolant pump connection.
- ▶ Immediately remove any coolant that does get into the device or spills onto the exterior of the device.

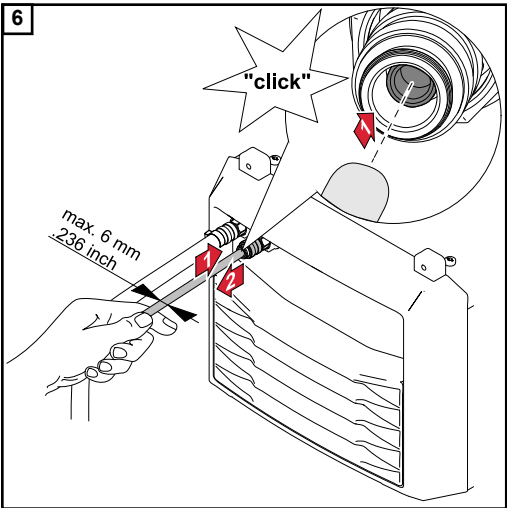
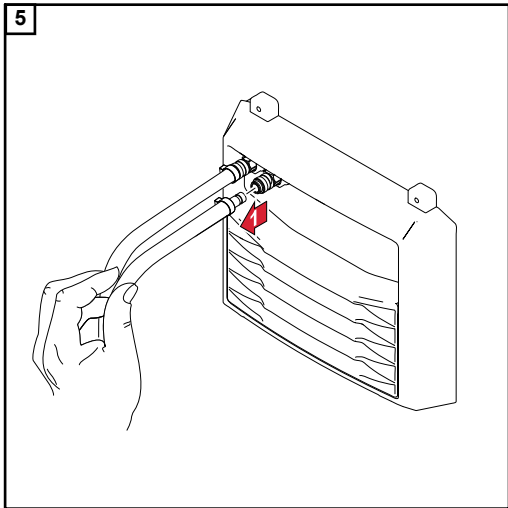
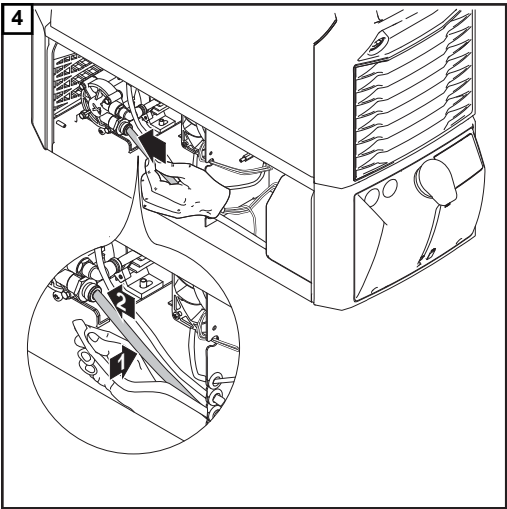
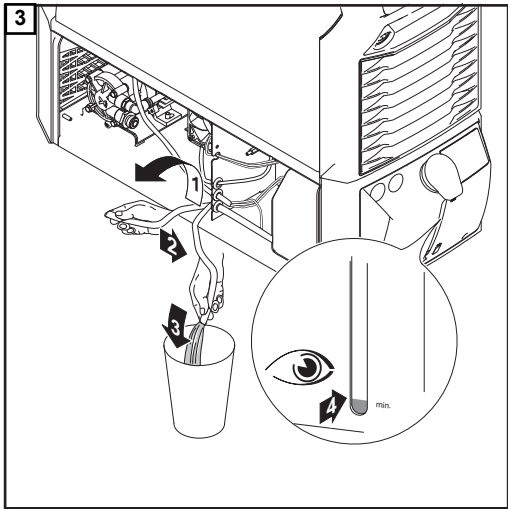

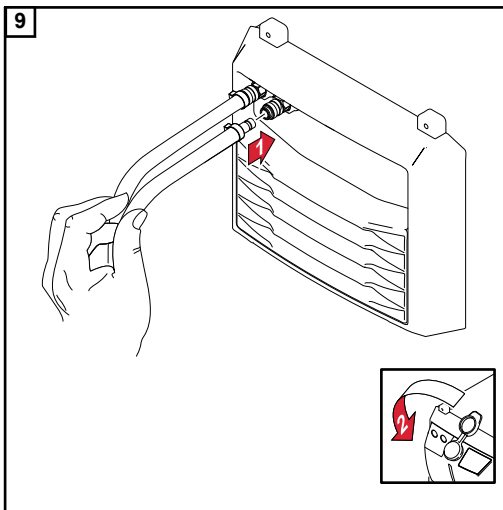
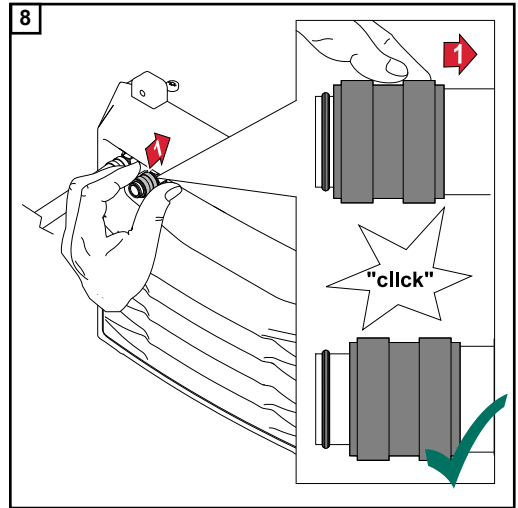
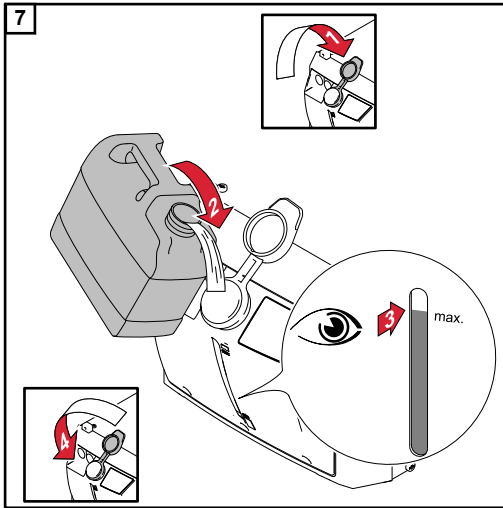

10 Ensure that all hose connections are properly established and are not leaking

11 Ensure that there is no coolant inside the device or on its exterior

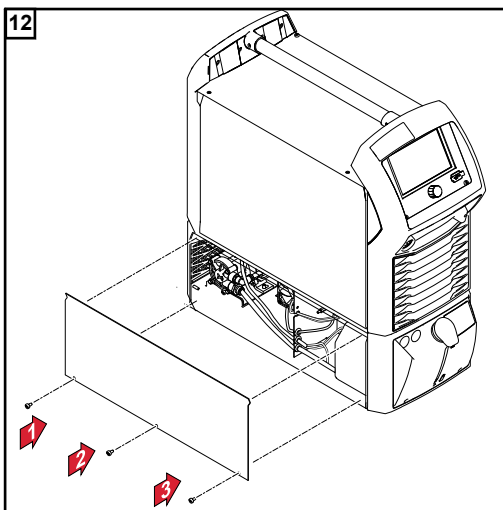

Disposal

Dispose of in accordance with the applicable national and local regulations.

Technical data

Technical data

- General**
- The cooling capacity of a cooling unit depends on
- Ambient temperature
 - Delivery head
 - Flow rate Q (l/min) - The flow rate Q depends on the length of the interconnecting hosepack and the diameter of the hose.

**CU 800i,
CU 800i /460 V**

	CU 800i
Mains voltage	400 V AC
Mains voltage tolerance	-10% / +10%
Grid frequency	50/60 Hz
Current consumption	0.7 A
Cooling capacity at Q = 1 l/min + 25 °C (77 °F)	800 W
Q = 1l / min + 40 °C (104 °F)	500 W
Q = max. + 25 °C (77 °F)	1160 W
Q = max. + 40 °C (104 °F)	730 W
Max. delivery head	35 m 114 ft 9.95 in.
Max. delivery rate	3.5 l/min 0.92 gal./min
Max. pump pressure	4.2 bar 60.92 psi
Pump	Centrifugal pump
Pump service life	approx. 10,000 hrs
Coolant capacity	4.5 l 1.19 gal.
Degree of protection	IP 23
Dimensions l/w/h	706/260/219 mm 27.8/10.24/8.62 in.
Weight (without coolant)	11.2 kg 24.69 lb
Flow monitoring* (sensor)	Warning between 1 and 0.7 l/min (0.26 - 0.18 gal./min), error message below 0.7 l/min (0.18 gal./ min)
Coolant temperature monitoring*	Warning above 68 °C (154.4 °F), error message above 70 °C (158 °F)
Level sensor* (functionality depends on the options installed in the device)	Warning or error message
Mark of conformity	CE

CU 800i /460 V	
Mains voltage	460 V AC
Mains voltage tolerance	-10% / +10%
Grid frequency	50/60 Hz
Current consumption	0.35 A
Cooling capacity at Q = 1 l/min + 25 °C (77 °F)	800 W
Q = 1l / min + 40 °C (104 °F)	500 W
Q = max. + 25 °C (77 °F)	1160 W
Q = max. + 40 °C (104 °F)	730 W
Max. delivery head	45 m 147 ft 7.65 in.
Max. delivery rate	2 l/min 0.53 gal./min
Max. pump pressure	5 bar 72.52 psi
Pump	Vane pump
Pump service life	approx. 10,000 hrs
Coolant capacity	4.5 l 1.19 gal.
Degree of protection	IP 23
Dimensions l/w/h	706/260/219 mm 27.8/10.24/8.62 in.
Weight (without coolant)	13.9 kg 30.64 lb
Flow monitoring* (sensor)	Warning between 1 and 0.7 l/min (0.26 - 0.18 gal./min), error message below 0.7 l/min (0.18 gal./ min)
Coolant temperature monitoring*	Warning above 68 °C (154.4 °F), error message above 70 °C (158 °F)
Level sensor* (functionality depends on the options installed in the device)	Warning or error message
Mark of conformity	CE, CSA

CU 800i Pro

If a TPS 270i C power source is used with a CU 800i Pro cooling unit, the cooling unit will not benefit from the maximum pump power.

Supply voltage	24 V DC
Current consumption	4.4 A
Cooling capacity at Q = 1 l/min + 25 °C (77 °F)	850 W
Q = 1l / min + 40 °C (104 °F)	510 W
Q = max. + 25 °C (77 °F)	1200 W
Q = max. + 40 °C (104 °F)	750 W
Max. delivery head	35 m 114 ft 9.95 in.
Max. delivery rate	3.5 l/min 0.92 gal./min
Max. pump pressure	4 bar 58.02 psi
Pump	Centrifugal pump
Pump service life	up to 20,000 hrs
Coolant capacity	4.5 l 1.19 gal.
Degree of protection	IP 23
Dimensions l/w/h	706/260/219 mm 27.8/10.24/8.62 in.
Weight (without coolant)	9.4 kg 20.72 lb
Flow monitoring* (sensor)	Warning between 1 and 0.7 l/min (0.26 - 0.18 gal./min), error message below 0.7 l/min (0.18 gal./ min)
Coolant temperature monitoring*	Warning above 68 °C (154.4 °F), error message above 70 °C (158 °F)
Level sensor* (functionality depends on the options installed in the device)	Warning or error message
Mark of conformity	CE, CSA

* Optional.

**CU 1100i,
CU 1100i /460 V**

	CU 1100i
Mains voltage	400 V AC
Mains voltage tolerance	-10% / +10%
Grid frequency	50/60 Hz
Current consumption	0.7 A
Cooling capacity at Q = 1 l/min + 25 °C (77 °F)	1100 W
Q = 1l / min + 40 °C (104 °F)	800 W
Q = max. + 25 °C (77 °F)	1500 W
Q = max. + 40 °C (104 °F)	1100 W
Max. delivery head	35 m 114 ft 9.95 in.
Max. delivery rate	3.5 l/min 0.92 gal./min
Max. pump pressure	4.2 bar 60.92 psi
Pump	Centrifugal pump
Pump service life	approx. 10,000 hrs
Coolant capacity	6 l 1.59 gal.
Degree of protection	IP 23
Dimensions l/w/h	710/300/230 mm 27.95/11.81/9.06 in.
Weight (without coolant)	13.6 kg 29.98 lb
Flow monitoring* (sensor)	Warning between 1 and 0.7 l/min (0.26 - 0.18 gal./min), error message below 0.7 l/min (0.18 gal./ min)
Coolant temperature monitoring*	Warning above 68 °C (154.4 °F), error message above 70 °C (158 °F)
Level sensor* (functionality depends on the options installed in the device)	Warning or error message
Mark of conformity	CE

CU 1100i /460 V	
Mains voltage	460 V AC
Mains voltage tolerance	-10% / +10%
Grid frequency	50/60 Hz
Current consumption	0.35 A
Cooling capacity at Q = 1 l/min + 25 °C (77 °F)	1100 W
Q = 1l / min + 40 °C (104 °F)	800 W
Q = max. + 25 °C (77 °F)	1500 W
Q = max. + 40 °C (104 °F)	1100 W
Max. delivery head	45 m 147 ft 7.65 in.
Max. delivery rate	2 l/min 0.53 gal./min
Max. pump pressure	5 bar 72.52 psi
Pump	Vane pump
Pump service life	approx. 10,000 hrs
Coolant capacity	6 l 1.59 gal.
Degree of protection	IP 23
Dimensions l/w/h	710/300/230 mm 27.95/11.81/9.06 in.
Weight (without coolant)	16.3 kg 35.94 lb
Flow monitoring* (sensor)	Warning between 1 and 0.7 l/min (0.26 - 0.18 gal./min), error message below 0.7 l/min (0.18 gal./ min)
Coolant temperature monitoring*	Warning above 68 °C (154.4 °F), error message above 70 °C (158 °F)
Level sensor* (functionality depends on the options installed in the device)	Warning or error message
Mark of conformity	CE, CSA

**CU 1100i /MV,
CU 1100i /MV
RVP**

	CU 1100i /MV
Mains voltage	200 - 230 V AC / 400 - 460 V AC
Mains voltage tolerance	-10% / +10%
Grid frequency	50/60 Hz
Current consumption	1.4 A / 0.7 A
Cooling capacity at Q = 1 l/min + 25 °C (77 °F)	1100 W
Q = 1l / min + 40 °C (104 °F)	800 W
Q = max. + 25 °C (77 °F)	1500 W
Q = max. + 40 °C (104 °F)	1100 W
Max. delivery head	35 m 114 ft 9.95 in.
Max. delivery rate	3.5 l/min 0.92 gal./min
Max. pump pressure	4.2 bar 60.92 psi
Pump	Centrifugal pump
Pump service life	approx. 10,000 hrs
Coolant capacity	6 l 1.59 gal.
Degree of protection	IP 23
Dimensions l/w/h	710/300/230 mm 27.95/11.81/9.06 in.
Weight (without coolant)	16.5 kg 36.38 lb
Flow monitoring* (sensor)	Warning between 1 and 0.7 l/min (0.26 - 0.18 gal./min), error message below 0.7 l/min (0.18 gal./ min)
Coolant temperature monitoring*	Warning above 68 °C (154.4 °F), error message above 70 °C (158 °F)
Level sensor* (functionality depends on the options installed in the device)	Warning or error message
Mark of conformity	CE, CSA

CU 1100i /MV RVP	
Mains voltage	200 - 230 V AC / 400 - 460 V AC
Mains voltage tolerance	-10% / +10%
Grid frequency	50/60 Hz
Current consumption	0.8 A / 0.35 A
Cooling capacity at Q = 1 l/min + 25 °C (77 °F)	1100 W
Q = 1l / min + 40 °C (104 °F)	800 W
Q = max. + 25 °C (77 °F)	1500 W
Q = max. + 40 °C (104 °F)	1100 W
Max. delivery head	45 m 147 ft 7.65 in.
Max. delivery rate	2 l/min 0.53 gal./min
Max. pump pressure	5 bar 72.52 psi
Pump	Vane pump
Pump service life	approx. 10,000 hrs
Coolant capacity	6 l 1.59 gal.
Degree of protection	IP 23
Dimensions l/w/h	710/300/230 mm 27.95/11.81/9.06 in.
Weight (without coolant)	16.5 kg 39.68 lb
Flow monitoring* (sensor)	Warning between 1 and 0.7 l/min (0.26 - 0.18 gal./min), error message below 0.7 l/min (0.18 gal./ min)
Coolant temperature monitoring*	Warning above 68 °C (154.4 °F), error message above 70 °C (158 °F)
Level sensor* (functionality depends on the options installed in the device)	Warning or error message
Mark of conformity	CE, CSA

* Optional.

**CU 1400i Pro,
CU 1400i Pro /MC**

If a TPS 320i C power source is used with a CU 1400i Pro or CU 1400i Pro /MC cooling unit, the cooling unit will not benefit from the maximum pump power.

CU 1400i Pro	
Supply voltage	24 V DC
Current consumption	4.4 A
Cooling capacity at Q = 1 l/min + 25 °C (77 °F)	1400 W
Q = 1l / min + 40 °C (104 °F)	900 W
Q = max. + 25 °C (77 °F)	1700 W
Q = max. + 40 °C (104 °F)	1250 W
Max. delivery head	35 m 114 ft 9.95 in.
Max. delivery rate	3 l/min 0.79 gal./min
Max. pump pressure at 4750 rpm	4 bar 58.02 psi
Pump	Centrifugal pump
Pump service life	up to 20,000 hrs
Coolant capacity	6 l 1.59 gal.
Degree of protection	IP 23
Dimensions l/w/h	710/300/230 mm 27.95/11.81/9.06 in.
Weight (without coolant)	12 kg 26.46 lb
Flow monitoring* (sensor)	Warning between 1 and 0.7 l/min (0.26 - 0.18 gal./min), error message below 0.7 l/min (0.18 gal./ min)
Coolant temperature monitoring*	Warning above 68 °C (154.4 °F), error message above 70 °C (158 °F)
Level sensor* (functionality depends on the options installed in the device)	Warning or error message
Mark of conformity	CE, CSA

CU 1400i Pro /MC	
Supply voltage	24 V DC
Current consumption	4.4 A
Cooling capacity at	
Q = 1 l/min + 25 °C (77 °F)	1400 W
Q = 1l / min + 40 °C (104 °F)	900 W
Q = max. + 25 °C (77 °F)	1700 W
Q = max. + 40 °C (104 °F)	1250 W
Max. delivery head	45 m 147 ft 7.65 in.
Max. delivery rate	3 l/min 0.79 gal./min
Max. pump pressure at 4750 rpm	4 bar 58.02 psi
Pump	Centrifugal pump
Pump service life	up to 30,000 hrs
Coolant capacity	6 l 1.59 gal.
Degree of protection	IP 23
Dimensions l/w/h	710/300/230 mm 27.95/11.81/9.06 in.
Weight (without coolant)	12 kg 26.46 lb
Flow monitoring* (sensor)	Warning between 1 and 0.7 l/min (0.26 - 0.18 gal./min), error message below 0.7 l/min (0.18 gal./ min)
Coolant temperature monitoring*	Warning above 68 °C (154.4 °F), error message above 70 °C (158 °F)
Level sensor* (functionality depends on the options installed in the device)	Warning or error message
Mark of conformity	CE, CSA

* Available as option on CU 1400i Pro. Installed as standard on the CU 1400i Pro /MC.

FRONIUS INTERNATIONAL GMBH

Froniusstraße 1
A-4643 Pettenbach
AUSTRIA
contact@fronius.com
www.fronius.com

Under **www.fronius.com/contact** you will find the addresses
of all Fronius Sales & Service Partners and locations



Find your
spareparts online



spareparts.fronius.com